

BAKER INDUSTRIES NORTHWEST

12428 Highway 99 South, Unit 56 • Everett, WA 98204-5502

Phone (425) 212-3169 • FAX (425) 353-6788

www.bakerindustriestnorthwest.com

Equipment Cabinets Model No. Designation

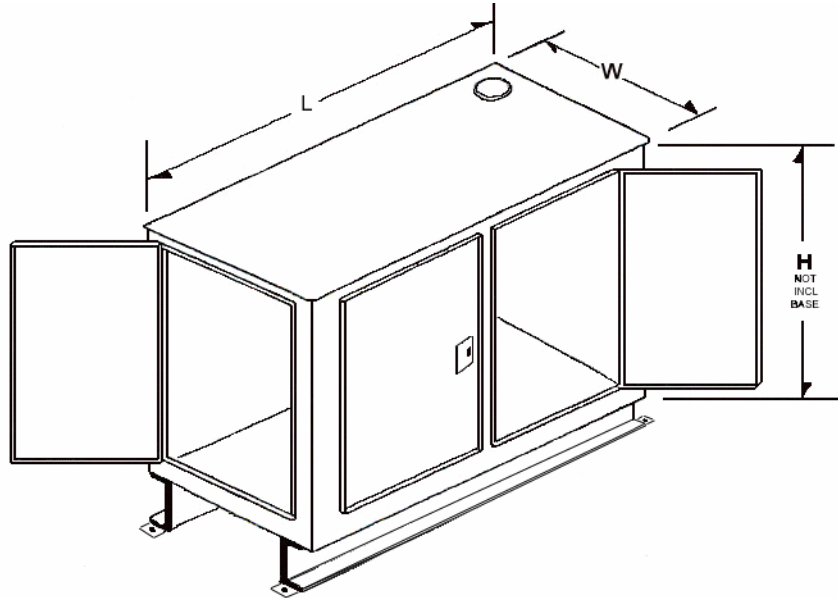

M/N 2100 (ST) – 96 - 48 - 42 - 2F - 1L - PF - WH
(L-in.) (W-in.) (H-in.) (Doors) (Doors) (Base) (Color)
Front L/R

“ST” All Baker series 2100 Cabinets are weather resistant, with flanged doors, entry sill, roof extensions, and leak-tight spill containment bottoms. By adding designation ST you specify the addition of door gaskets and draw latches for additional weather protection.

Base options are LL-no rise, PF-platform (typ. 4” rise), SK-skid (typ. 6” rise), P-pedestal (varies with cabinet size).

White powdercoat finish (int/ext) is standard. BL=blue, BK=black, GR=green, GY-grey, RD=red, CC=custom color.

To designate stainless steel cabinet construction, enter SSI (type 304) or SS2 (type 316) where color would normally go.

Ventillation: These cabinets are built and tested to contain small product leaks. Consequently they must remain vented to atmosphere. A top opening is provided in each cabinet for that purpose.

Grounding: Each cabinet is provided with a 3/8” dia. electrical grounding stud. The cabinet must be grounded in accordance with local electrical codes when installed.

